

General system requirements for the 32 bit and 64 bit edition of **CONTROL** are detailed below. Use this box to navigate the information.

Recommended Requirements	
32 Bit	64 Bit
<a href="#">2-Tier Architecture</a>	<a href="#">2-Tier Architecture</a>
<a href="#">3-Tier Architecture</a>	<a href="#">3-Tier Architecture</a>

## 2-Tier Architecture Recommended Requirements -32 bit

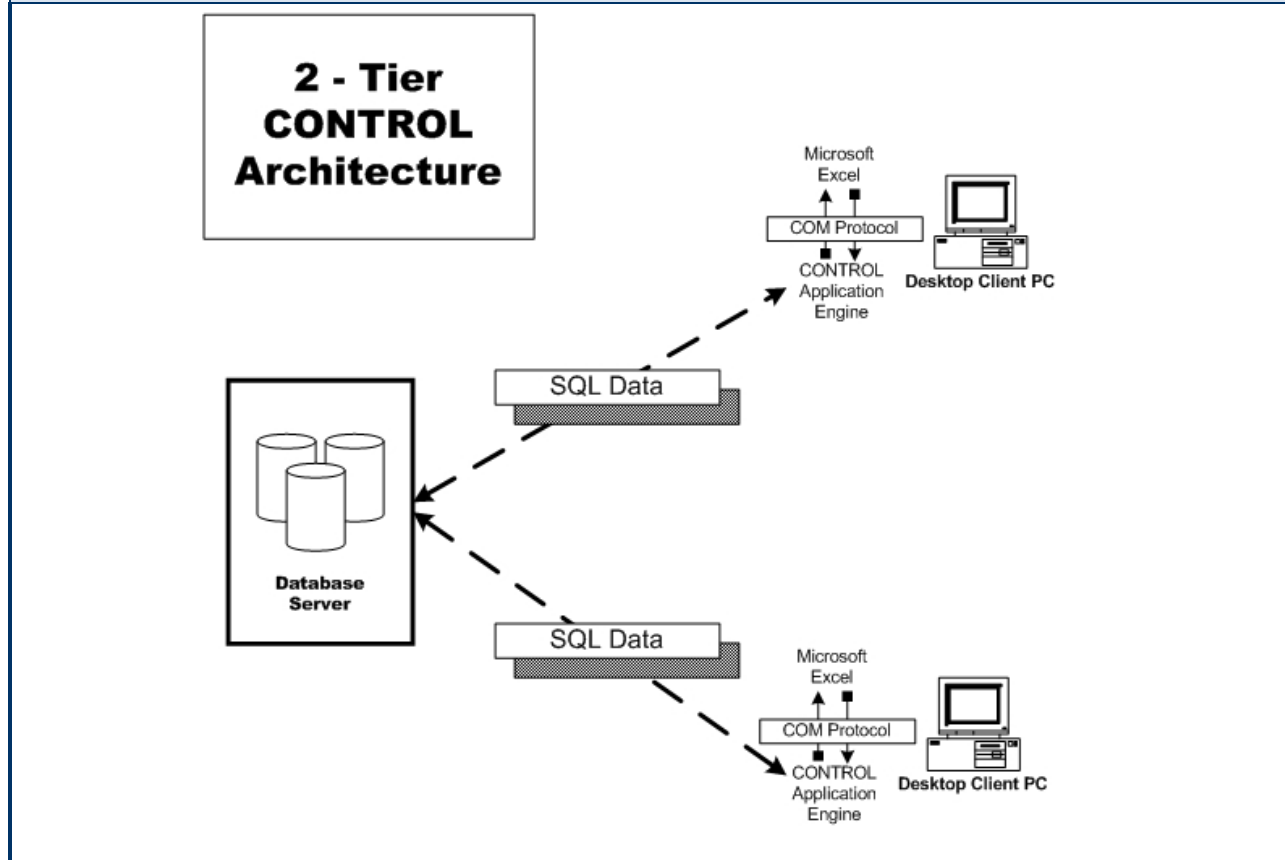

Type of Installation	Hardware	Operating System	Software	SQL Database Client Software	Disk Space
Excel Client*	1 GB of RAM 1-gigahertz (GHz) or faster CPU	Windows XP, Vista or 7	Excel 2003/2007/2010  (2007 must be SP2 or later)  Microsoft .NET Framework 3.5	Yes	150 MB

[Return to Recommended Requirements Summary](#)

## 3-Tier Architecture Recommended Requirements -32 bit

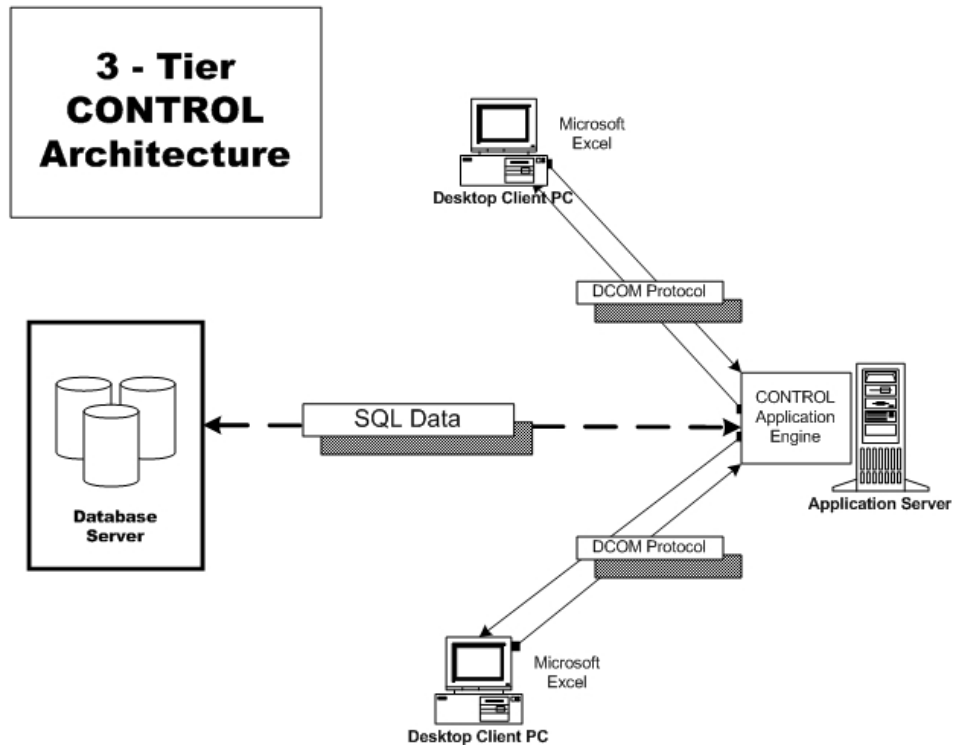

Type of Installation	Hardware	Operating System	Software	SQL Database Client Software	Disk Space
Excel Client*	1 GB of RAM 1-gigahertz (GHz) or faster CPU	Windows XP, Vista or 7	Excel 2003/2007/2010  (2007 must be SP2 or later)  Microsoft .NET Framework 3.5	No	150 MB
Application Server **	2 GB of RAM 2-gigahertz (GHz) or faster CPU	Windows 2003, 2008 or 2008R2 server	Microsoft .NET Framework 3.5	Yes	200 MB

[Return to Recommended Requirements Summary](#)

\* Memory requirements are guidelines and are subject to change based on your requirements and data volumes.

\*\*Server sizing is approximated. Actual requirements will vary based on the required dimensionality, the cardinality of each dimension, the number of scenarios, time horizons, the number of concurrent users of the implementation will support, data volumes, etc.

## 2-Tier Architecture Recommended Requirements -64 bit

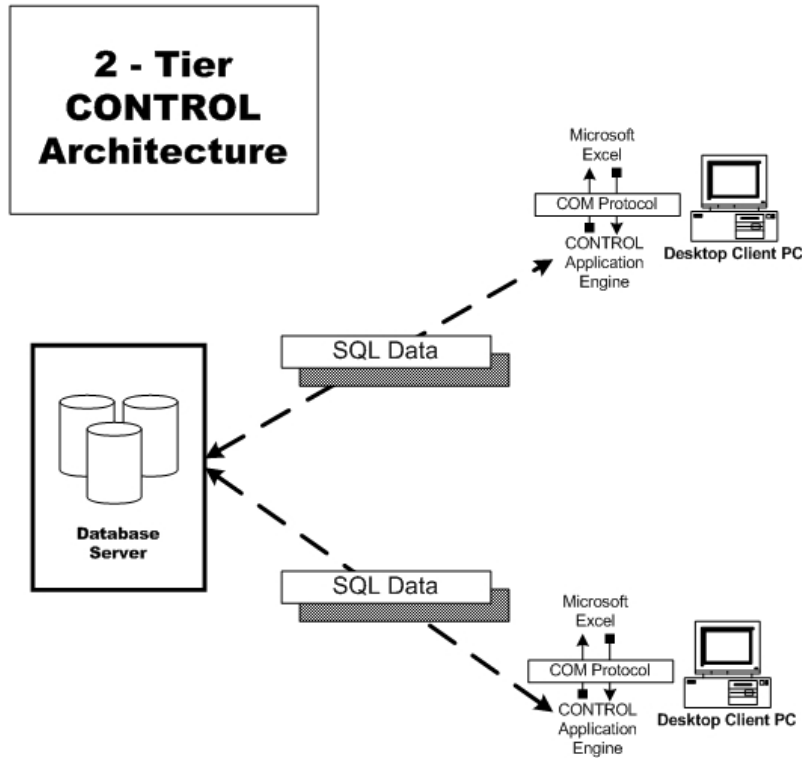

Type of Installation	Hardware	Operating System	Software	SQL Database Client Software	Disk Space
Excel Client (32 bit)*	1 GB of RAM 1-gigahertz (GHz) or faster CPU	Windows XP, Vista or 7	Excel 2003/2007/2010  (2007 must be SP2 or later)  Microsoft .NET Framework 3.5	Yes	150 MB
--- Or --- Excel Client (64 bit)*	--- Or --- 1 GB of RAM Intel P4 or Xeon/AMD x64 CPU	--- Or --- Windows XP x64, Vista x64 or 7 x64	--- Or --- Excel 2003/2007/2010  (2007 must be SP2 or later)  Microsoft .NET Framework 3.5	--- Or --- Yes	-- Or -- 150 MB

[Return to Recommended Requirements Summary](#)

## 3-Tier Architecture Recommended Requirements -64 bit

### 3 - Tier CONTROL Architecture

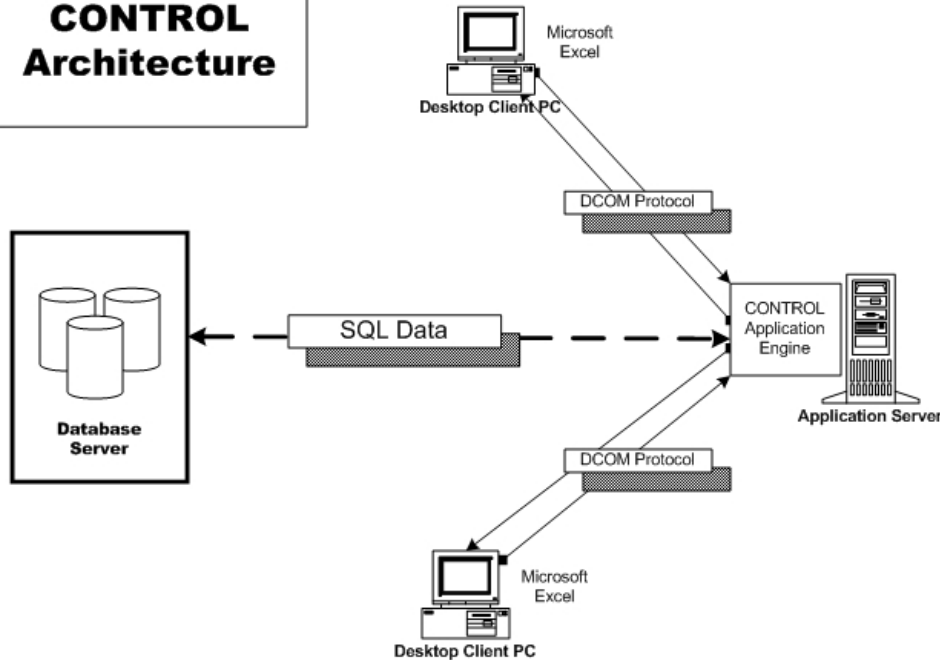

Type of Installation	Hardware	Operating System	Software	SQL Database Client Software	Disk Space
Excel Client (32 bit)*	1 GB of RAM	Windows XP, Vista or 7	Excel 2003/2007/2010 (2007 must be SP2 or later)	Yes	150 MB
--- Or --- Excel Client (64 bit)*	1-gigahertz (GHz) or faster CPU --- Or --- 1 GB of RAM Intel P4 or Xeon/AMD x64 CPU	--- Or --- Windows XP x64, Vista x64 or 7 x64	Microsoft .NET Framework 3.5	--- Or --- Yes	-- Or -- 150 MB
Application Server (32 bit) **	2 GB of RAM	Windows 2003, 2008 or 2008R2 server	Microsoft .NET Framework 3.5	Yes	200 MB
--- Or --- Application Server (64 bit) **	2-gigahertz (GHz) or faster CPU --- Or --- 2 GB of RAM Intel P4 or Xeon/AMD x64 CPU	--- Or --- Windows 2003 x64, 2008 x64 or 2008R2 x64 server		--- Or --- Yes	-- Or -- 200 MB

[Return to Recommended Requirements Summary](#)

- \* Memory requirements are guidelines and are subject to change based on your requirements and data volumes.
- \*\*Server sizing is approximated. Actual requirements will vary based on the required dimensionality, the cardinality of each dimension, the number of scenarios, time horizons, the number of concurrent users of the implementation will support, data volumes, etc.